

# INSTRUCTION MANUAL

## PHV-200 Mechanical/Hydraulic Machine Vice 200mm

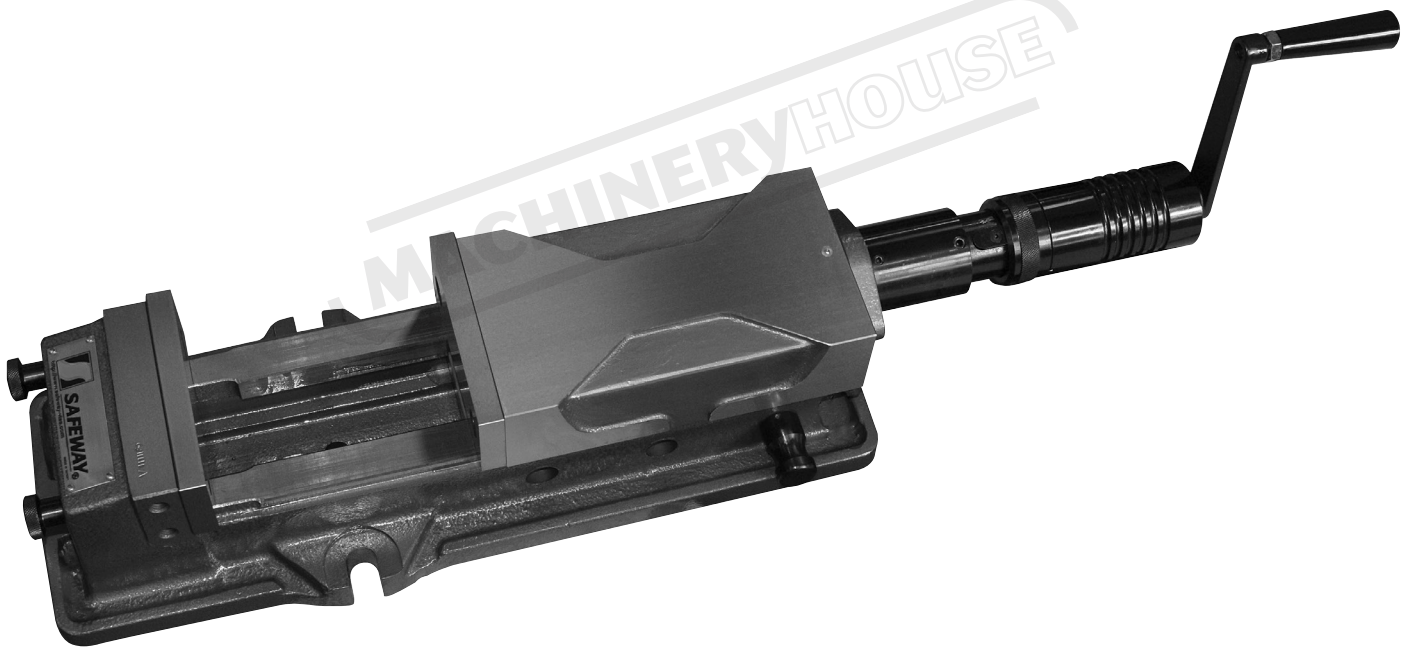

V334

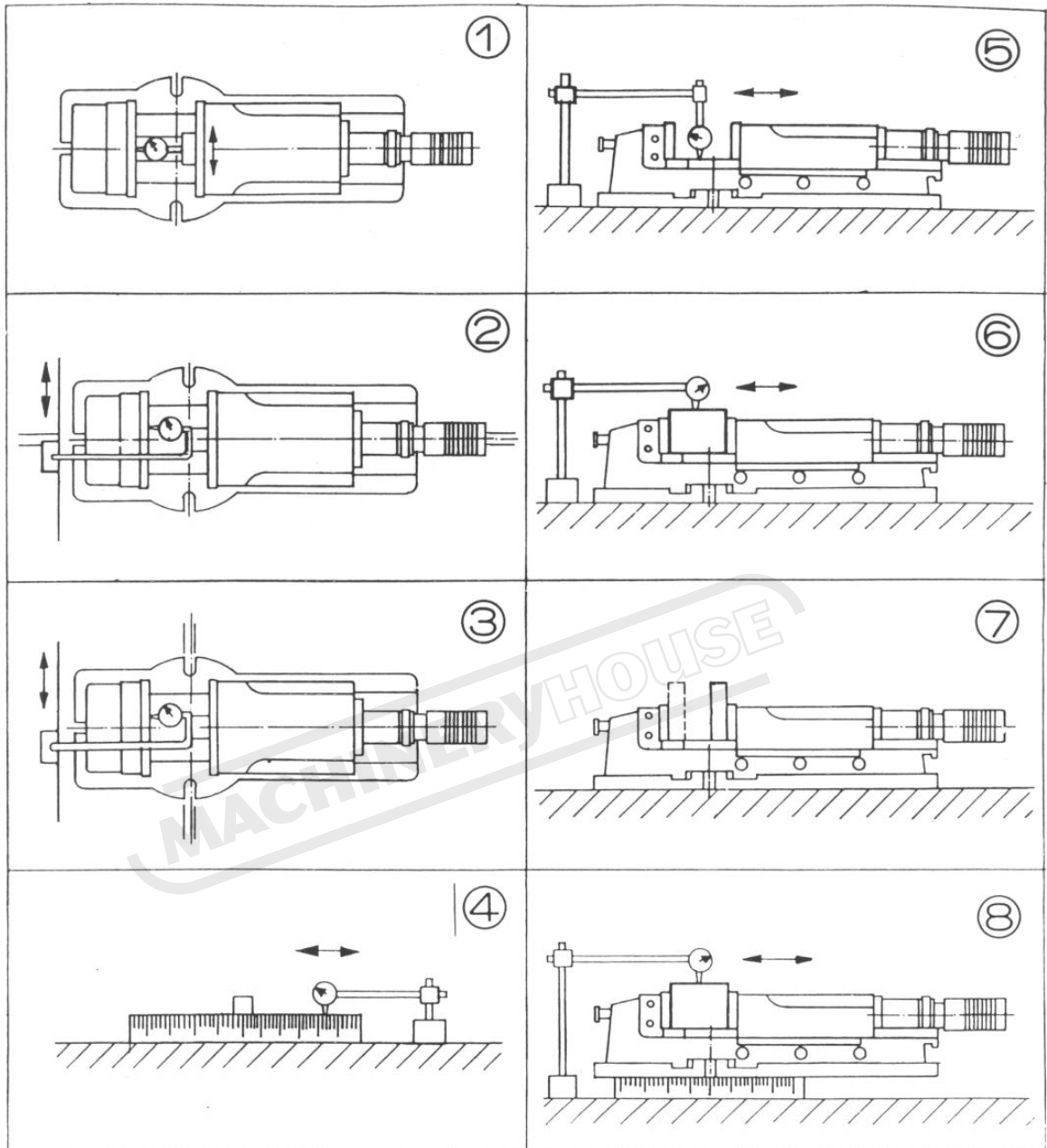

NO.	Test Item	JIS Grade 1	Guaranteed
1.	Both jaw plate parallel.	0.020 100mm	0.020 100mm
2.	Keyways on bottom of vise bed square to clamping surface of jaw plate.	0.020 100mm	0.015 100mm
3.	Keyways on bottom of vise bed parallel to clamping surface of jaw plate.	0.020 100mm	0.015 100mm
4.	Swivel base parallel.	0.200 100mm	0.015 100mm
5.	Surface of vise bed parallel to bottom of vise body.	0.020 100mm	0.010 100mm
6.	Top of rectangular test block clamped tightly by jaws parallel to bottom of vise body.	0.030 100mm	0.020 100mm
7.	Clamping surface of jaw plate perpendicular to vise bed, the angle always being less than 90°.	0.050 100mm	0.030 100mm
8.	Top of rectangular test block clamped tightly by jaws parallel to bottom of swivel base.	0.040 100mm	0.030 100mm

## BEFORE OPERATION CHECK THE FOLLOWING

1. Check the accuracy sheet and attachment
2. Remove the protective layers of grease and rust preventive before moving the slides.
3. Lubricate all slide ways and lubrication points
4. After setting the vice to the work piece size check that the lock pin is securely through the side of the vice and the centre block. Not in front or behind the centre block.
5. Insure that the vice is balanced before lifting

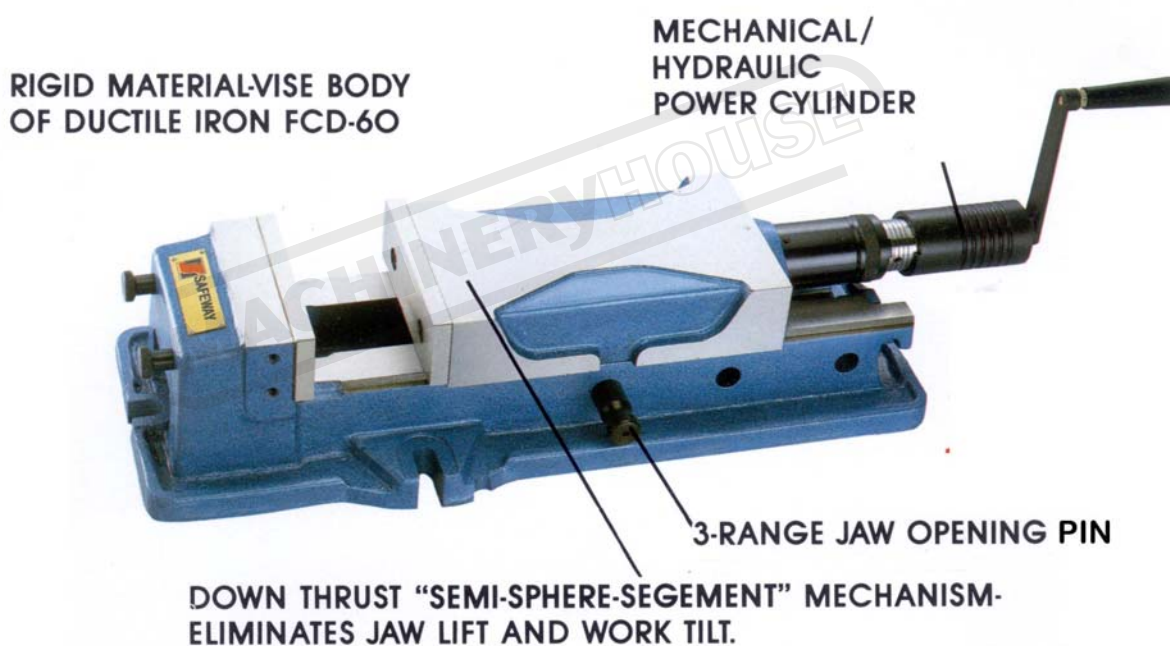

## FEATURES

1. Mechanical/Hydraulic spindle
2. Down thrust "Semi-sphere Segment" mechanism eliminates jaw lift and work tilting
3. All surfaces ground
4. Rigid vice body manufactured from ductile iron FCD 60JIS (equal to GGG60) with 60kgs/mm or 80888 psi tensile strength
5. Vice bed flame hardened to HRC 45 to minimise wear and maintain accuracy

**BEFORE INSTALLING VICE ON THE TABLE**

1. Insure that the bottom of the vice the table and the Tee slots are clean and free of swarf.
2. Secure the tee slot blocks provided into the base of the vice with the Allen head screws.

**Note!** Make sure that the tee slot blocks are the correct size for the table slots. If oversize machine to the correct size taking the material off one side only.

3. Lift the vice using the mounting lugs provided



← 2 KGS of power in this direction.  
 Produce 1KG of downward.  
 ↓ Down thrust "Semi-Sphere Segment"  
 mechanism-eliminates jawlift and work tilt.

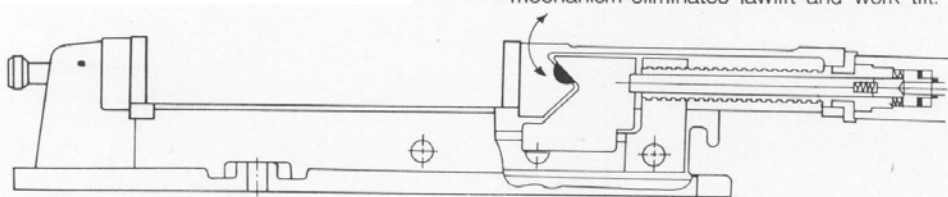

**HOW TO CORRECT FIXTURE MACHINE VISE**

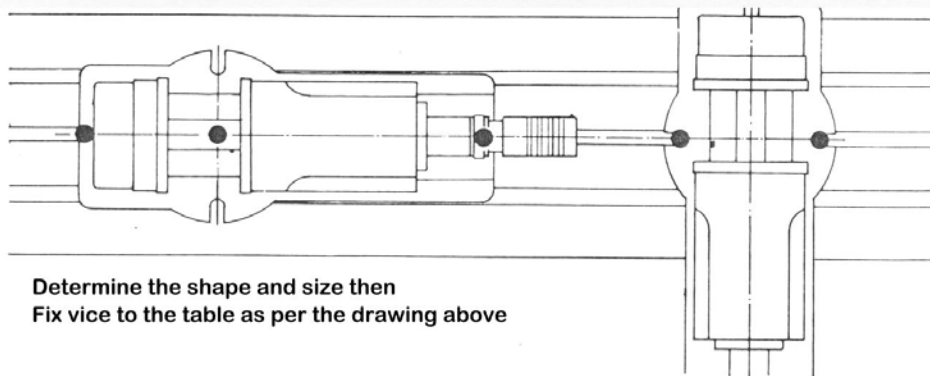

**Determine the shape and size then  
Fix vice to the table as per the drawing above**

### OPERATING INSTRUCTIONS

#### 1. CLAMPING WITH HYDRAULIC POWER

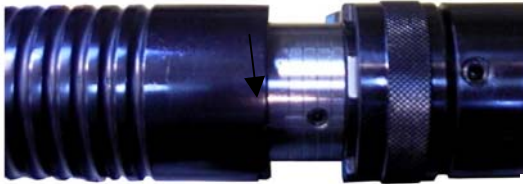

- a. Insure that the four lines on the hydraulic spindle 34 are visible. To bring them into full view hold the cylinder 35 body and turn the spindle 32 counter clockwise.

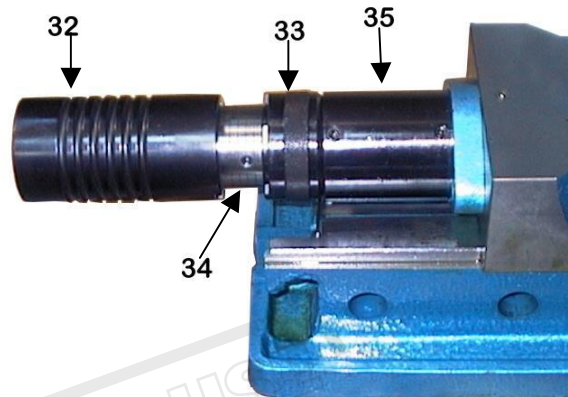

- b. Slide the collar 33 to the non en-gauge position.
- c. Turn the handle clockwise to bring the movable jaw into the work piece



- d. The vice will lock up as a mechanical vice. When the handle starts to tighten bump the handle sharply clock wise with your hand and the hydraulic mechanism will commende. The spindle 34 will remain stationary and the outer handle

will turn.

- e. The lines engraved on spindle 34 can be used as a guide to indicate the amount of pressure applied to the job. Maximum pressure is obtained when all the lines have been covered.



- f. To undo the vice wind the handle anti clock wise. The outer spindle 32 will rotate with 34 remaining stationary until the hydraulic system has reached its home position the spindle 34 will rotate to undo the mechanical side of the system.

**HOW TO PUT OIL INTO BOSTER AS FOLLOWING: (PAT. 45716)**

1. Hold the cylinder 28, knock handle clockwise until the clutch 38 39 non-engagement.
2. Loosen oil hole plug 29, and continue turn handle clockwise, until the air from boster by pressed.
3. Drop oil (R-68) into the boster hole, simultaneous turn handle counter clockwise. Untile the boster oil full. (Maybe twice)
4. Tightly the boster plug 29 and try clamping.
5. Loosen set screw 35 and boster plug 29 again.
6. Hold the cylinder 28, use handle turn collar 65 counter clockwise simultaneous drop oil into boster again. Until the cylinder 37 loosen 8-10m/m, then tightly boster plug 29 and turn collar 65 clockwise tightly set screw 36. You can finished pre-pressure.
7. Check clamping force whether OK!

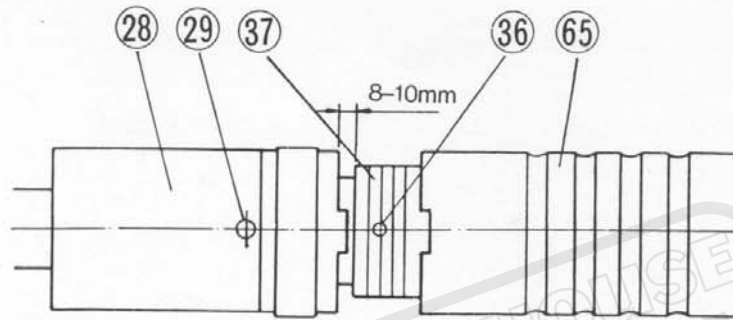

**HOW TO CORRECT CLAMPING YOUR WORKPIECE**

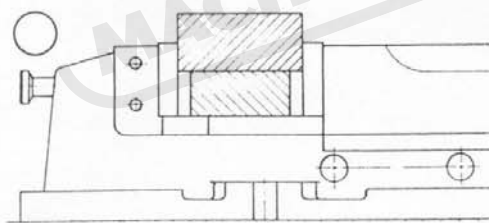

Correct

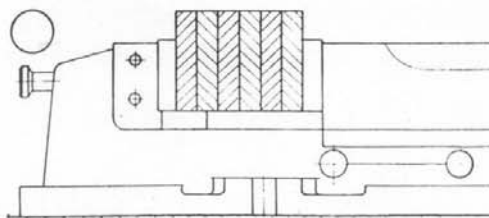

Correct

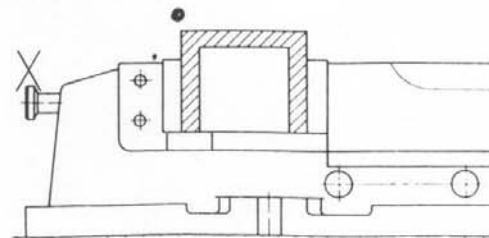

The workpiece itself will become bendable after clamping.

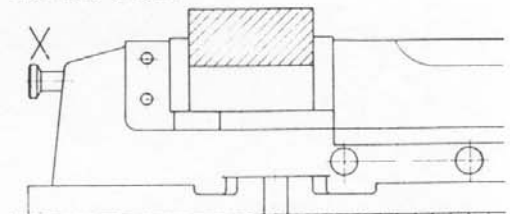

The bottom of workpiece is suspensible and it is not easy to take the resistance of cutting, then it will loosen or move secretly.

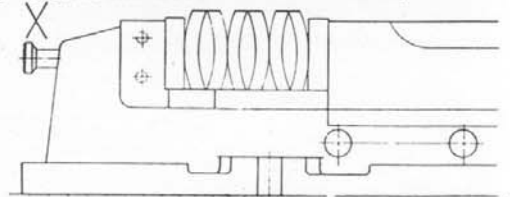

The workpiece itself is difficult to clamp and easing deformed after clamping.

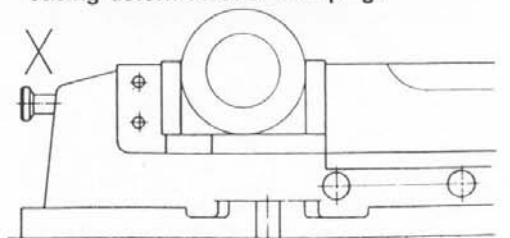

Use CJ-Jaw plates

**DIMENSIONS**

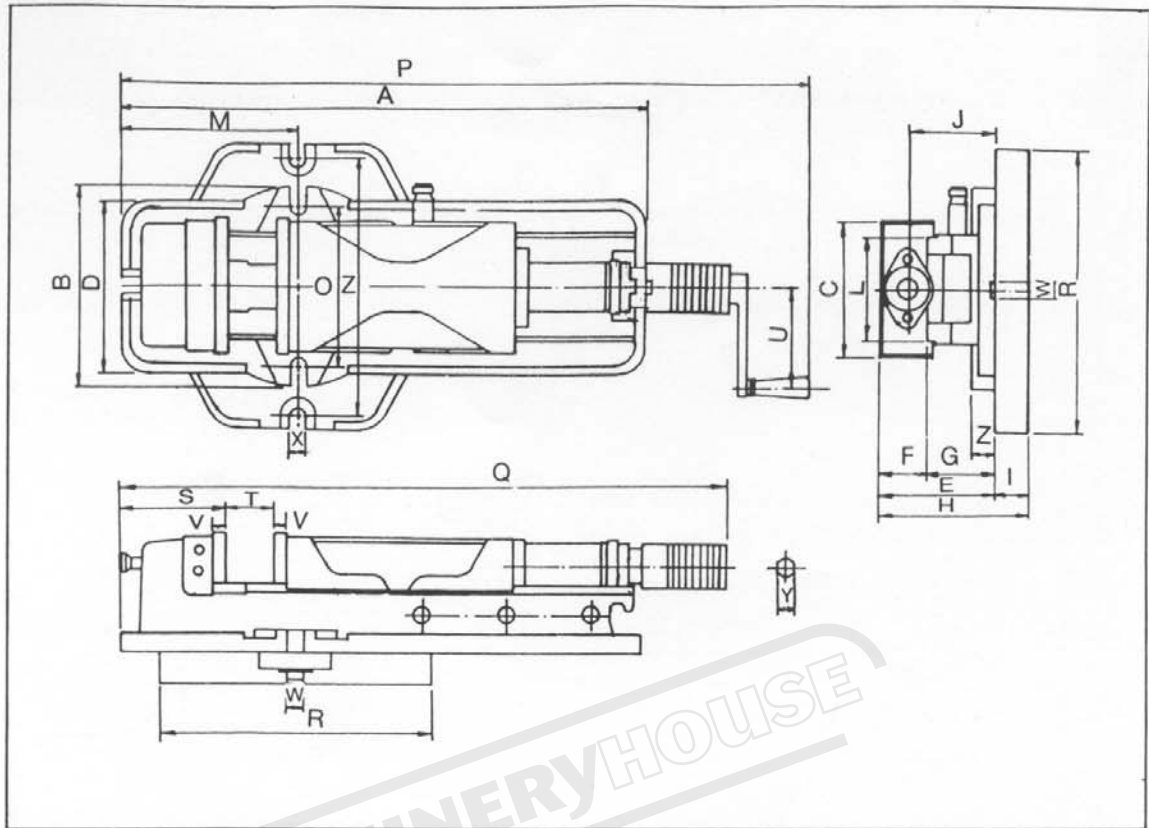

MODEL	PHV-130	PHV-160	PHV-200	PHV-250	MODEL	PHV-130	PHV-160	PHV-200	PHV-250
A	505	625	700	810	Q	570 795	625 935	725 1035	815 1155
B	190	240	280	320	R	260	320	360	420
C	130	160	200	250	S	105	125	150	180
D	170	205	240	290	T	225	310	310	345
E	127	140	163	180	U	125	125	125	125
F	55	58	63	80	V	15	15	18	21
G	72	82	100	105	W	16	16	18	18
H	161	178	209	230	X	18	18	22	22
I	34	38	46	50	Y	14	14	14	14
J	97	105	125	134	Z	25	27	36	36
K	290	340	400	460	Jaw Opening Position I	0-75	0-110	0-110	0-115
L	106	125	165	195	II	70-150	100-210	100-210	100-230
					III	145-225	200-310	200-310	225-340
M	180	208	265	320	Max. Hydraulic Pressure	3500	4000	6000	7000
N	250	300	360	410	Limit Pressure	4000	5000	7000	8000
O	160	196	240	270	Weight Vise Only	37	57	89	146
P	695 920	750 1060	830 1140	920 1260	Swivel Base	9	15	29	35

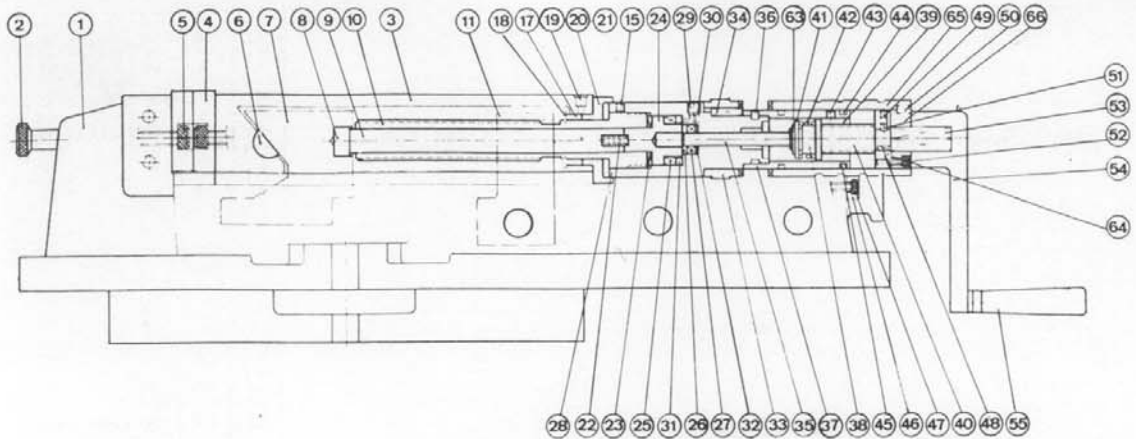

**HOW TO ORDER SPARE PARTS**

130  
160  
200  
250

PHV- -000-000000-00

Qty  
Mfg. No.  
Part No.

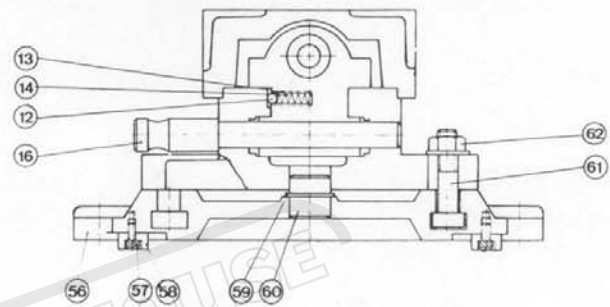

No.	Part No.	Part Name	Qty	Remark	No.	Part No.	Part Name	Qty	Remark
1	130, 160, 200, 250-001	Main body	1		34	" -034	Key	1	
2	" -002	Shackle	2		35	" -035	Push rod	1	
3	" -003	Movable	1		36	" -036	Set screw	1	
4	" -004	Jaw plates	2		37	" -037	Clutch holder	1	
5	" -005	Socket cap screw	4		38	" -038	Clutch	1	
6	" -006	Semi-sphere segment	1		39	" -039	Clutch	1	
7	" -007	Lock down body	1		40	" -040	Minor screwrod	1	
8	" -008	Power pad	1		41	" -041	Washer	1	
9	" -009	Power shaft	1		42	" -042	Spring	1	
10	" -010	Main screw	1		43	" -043	Set screw	1	
11	" -011	Main screw nut	1		44	" -044	Roll	8	
12	" -012	Steel ball	1		45	" -045	Steel ball	54	
13	" -013	Steel ball holder	1		46	" -046	Stopper	1	
14	" -014	Spring	1		47	" -047	Socket cap screw	2	
15	" -015	Set screw	3		48	" -048	Set screw	2	
16	" -016	Lock pin	1		49	" -049	Set screw	2	
17	" -017	Sleeve	1		50	" -050	Set screw	3	
18	" -018	Pin	4		51	" -051	Set screw	1	
19	" -019	Oil cap	1		52	" -052	Socket cap screw	3	
20	" -020	Main screw rod metal	1		53	" -053	Handle Hex.	1	
21	" -021	Socket cap screw	2		54	" -054	Handle	1	
22	" -022	Spring	1		55	" -055	Handle grip	1	
23	" -023	Disc spring	2		56	" -056	Swivel base	1	
24	" -024	Piston	1		57	" -057	Socket cap screw	2	
25	" -025	Oil packing	1		58	" -058	Key block	2	
26	" -026	Packing ring	1		59	" -059	Sanp ring	1	
27	" -027	Oil packing	1		60	" -060	Swivel base shaft	1	
28	" -028	Cylinder body	1		61	" -061	t-slot bolts	2	
29	" -029	Oil plug	1		62	" -062	Swivel base nut	2	
30	" -030	Oil plug seal	1		63	" -063	Snap ring	1	
31	" -031	Boster ring	1		64	" -064	Minor screwrod collar	1	
32	" -032	Backup ring	1		65	" -065	Collar	1	
33	" -033	Collar	.1		66	" -066	Handle joint	1	

**PJ-JAW PLATE**

PJ	130	160	200	250
A	90	90	120	160
B	130	160	200	250
C	25	25	28	35
D	55	58	63	80
E	15	15	18	21

**RJ-JAW PLATE**

RJ	130	160	200	250
A	90	90	120	160
B	130	160	200	250
C	25	25	28	35
D	55	58	63	80
E	15	15	18	21

**DJ-JAW PLATE**

DJ	130	160	200	250
A	90	90	120	160
B	130	160	200	250
C	25	25	28	35
D	55	58	63	80
E	32	32	40	40

**CJ-JAW PLATE**

CJ	130	160	200	250
A	90	90	120	160
B	130	160	200	250
C	25	25	28	35
D	55	58	63	80
E	32	32	40	40
F	55	55	70	70
G	12	12	12	12
H	25	25	30	30

**SWIVEL BASE**

SB	130	160	200	250
A	290	340	400	460
B	260	320	360	420
C	34	39	46	50
D	18	18	22	22

KT	130	160	200	250
A	29	29	38	46
B	14	14	15	15
C	32	32	32	45
D	M10	M10	M10	M10

## OTHER PRODUCTS

Compact CNC Vice



Double Lock CNC Vice



Air Operated Production Vice

